





















ASSEMBLY INSTRUCTION

MODEL: SB88105KFW

DESCRIPTION: KING SLEIGH BED

PART LIST				PART LIST				
NO	DESCRIPTION	SKETCH	QTY		DESCRIPTION	SKETCH	SIZE	QTY
A	HEADBOARD		1 PC	1.	BOLT		M8 X 50mm	2 PCS
B	FOOTBOARD		1 PC	2.	BOLT (LOCK WASHER+FLAT WASHER)		M8 X 50mm	6 PCS
C	SIDE RAIL(LEFT & RIGHT)		2 PCS	3.	BOLT (LOCK WASHER+FLAT WASHER)		M8 X 25mm	28 PCS
D	HEADBOARD SUPPORT		1 PC	4.	BOLT (LOCK WASHER+FLAT WASHER)		M6 X 35mm	6 PCS
E	HEADBOARD LEGS (LEFT&RIGHT)		2 PCS	5.	BOLT (LOCK WASHER+FLAT WASHER)		M6 X 25mm	2 PCS
F	FOOTBOARD LEGS		2 PCS	6.	SCREWS		M4 X 32mm	12 PCS
G	SLATS		14 PCS	7.	ALLEN KEY		M4	1 PC
H	SUPPORT LEGS		3 PCS	8.	ALLEN KEY		M5	1 PC
I	CENTER WOOD SUPPORT		1 PC	9.	PHILIPS HEAD SCREWDRIVER		NO INCLUDED	
J	SIDE RAIL BRACKET		4 PCS					
K	CENTER WOOD BRACKET		2 PCS					

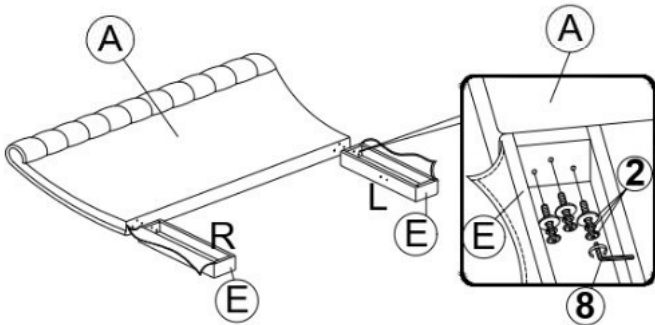

STEP 1 :

ASSEMBLY HEADBOARD LEG (E) WITH HEADBOARD (A) BY USING BOLT (2) (LOCK WASHER + FLAT WASHER) & ALLEN KEY (8)

Do not tighten the bolt until the headboard support assembly with the headboard legs (left & right).

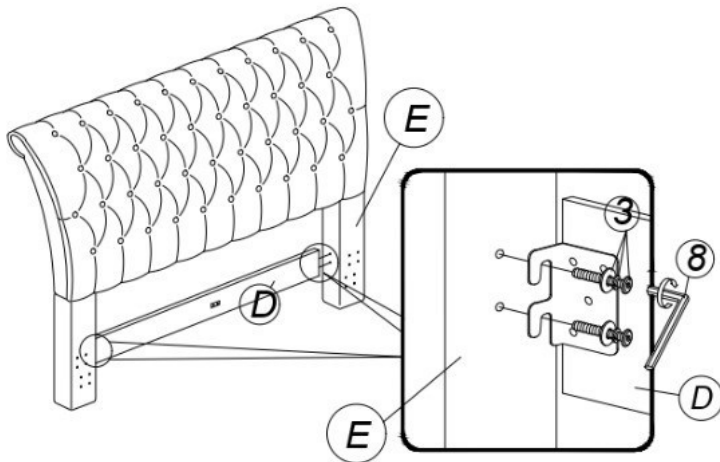

STEP 2 :

ASSEMBLY HEADBOARD SUPPORT (D) WITH HEADBOARD LEG (E) (LEFT & RIGHT) BY USING BOLT (3) (LOCK WASHER + FLAT WASHER) & ALLEN KEY (8)

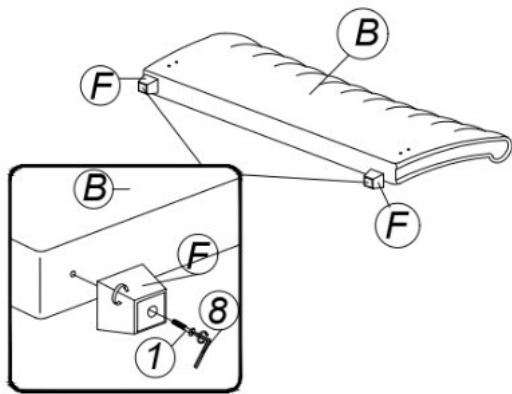

STEP 3 :

ASSEMBLY FOOTBOARD (B) WITH FOOTBOARD LEG (F) BY USING BOLT (1) & ALLEN KEY (8)

STEP 4 :

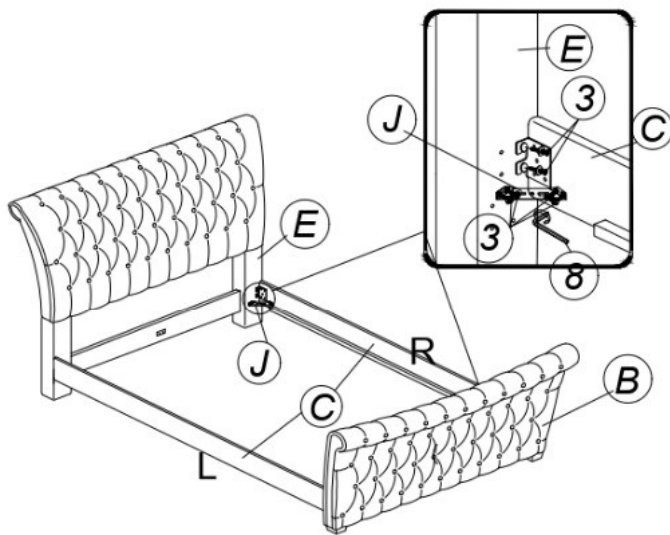

A) ASSEMBLY SIDE RAIL (LEFT & RIGHT) (C) WITH HEADBOARD LEG (E) & FOOTBOARD (B) BY USING BOLT (3) (LOCK WASHER + FLAT WASHER) & ALLEN KEY (8)

B) ASSEMBLY SIDE RAIL BRACKET (J) WITH SIDE RAIL (C) & HEADBOARD LEG (E) (LEFT & RIGHT) BY BOLT (3) (LOCK WASHER + FLAT WASHER) & ALLEN KEY (8)

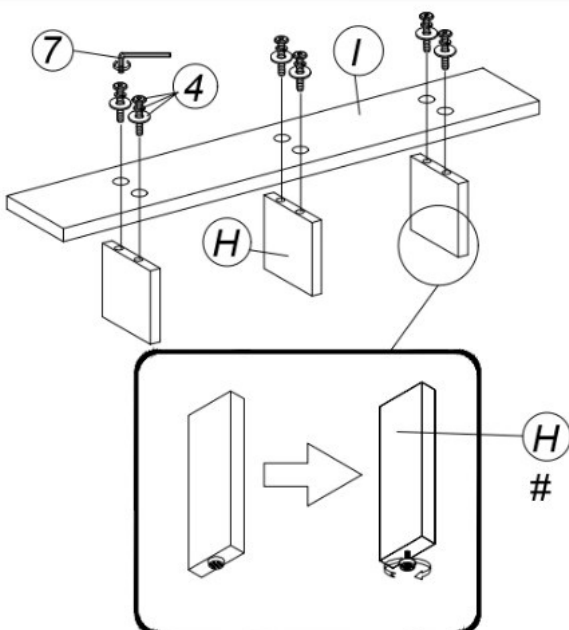

STEP 5 :

ASSEMBLY SUPPORT LEG (H) TO CENTER WOOD SUPPORT (I) BY USING BOLT (4) (LOCK WASHER + FLAT WASHER) & ALLEN KEY (7)

The Glides under the support legs can be adjusted later to keep the slats level on uneven surfaces

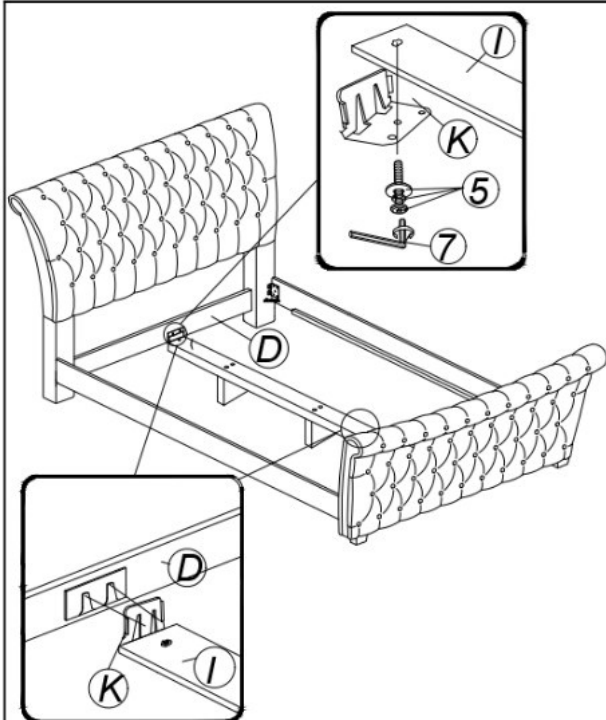

STEP 6 :

- A) ASSEMBLY CENTER WOOD BRACKET (K) WITH CENTER WOOD SUPPORT (I) BY USING BOLT (5) (LOCK WASHER + FLAT WASHER) & ALLEN KEY (7)
- B) ASSEMBLY HEADBOARD SUPPORT (D) & FOOTBOARD (B) WITH CENTER WOOD BRACKET (K)

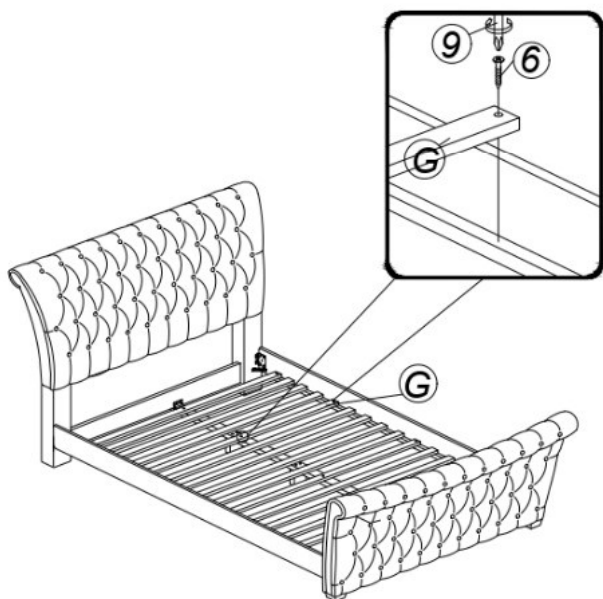

STEP 7 :

- A) SECURE SLATS (G) WITH SCREW (6) BY PHILIPS HEAD SCREWDRIVER (9) (no included)

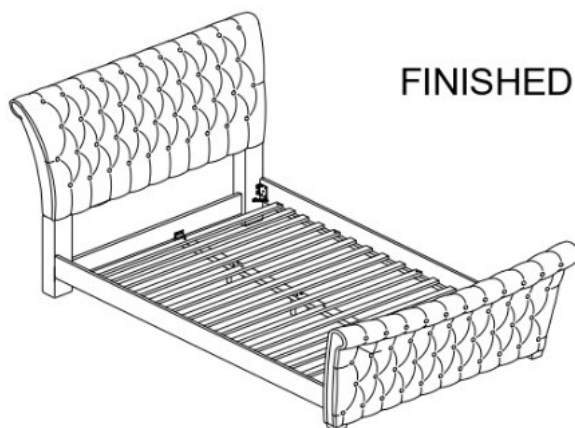

FINISHED